

- Complies with American National Standard Z358.1
- Chrome-Plated Brass Pipe and Fittings
- Universal Identification Sign and Inspection Tag Included
- Full, One-Year Warranty
- Classified by Underwriters Laboratory Inc. to ANSI Z358.1



## Specifications

Unit design saves space and fits easily into any work environment. Eye and eye/face wash units operate quickly by a large, highly visible push handle. Safe, steady water flow under varying water supply conditions from 30–90 PSI is assured by integral flow control in the sprayhead assembly. NOTE: The ANSI Z358.1 standard requires an uninterrupted supply of flushing fluid at a minimum 30 PSI flowing pressure.

*This plumbing fixture is not intended to dispense water for human consumption through drinking or for preparation of food or beverages.*

## Standard Equipment

### Eye/Face Wash Sprayhead Assembly

Twin ABS plastic perforated-disc eye/face wash sprayheads with protective sprayhead covers. Safe, steady water flow under varying water supply conditions from 30–90 PSI is assured by integral flow control in the sprayhead assembly.

### Valve

Chrome-plated brass ½" NPT stay-open ball valve. Hand operated by a large, highly visible safety yellow PVC push handle.

### Pipe and Fittings

Chrome-Plated Brass Pipe and Fittings.

### Water Supply

½" NPT.

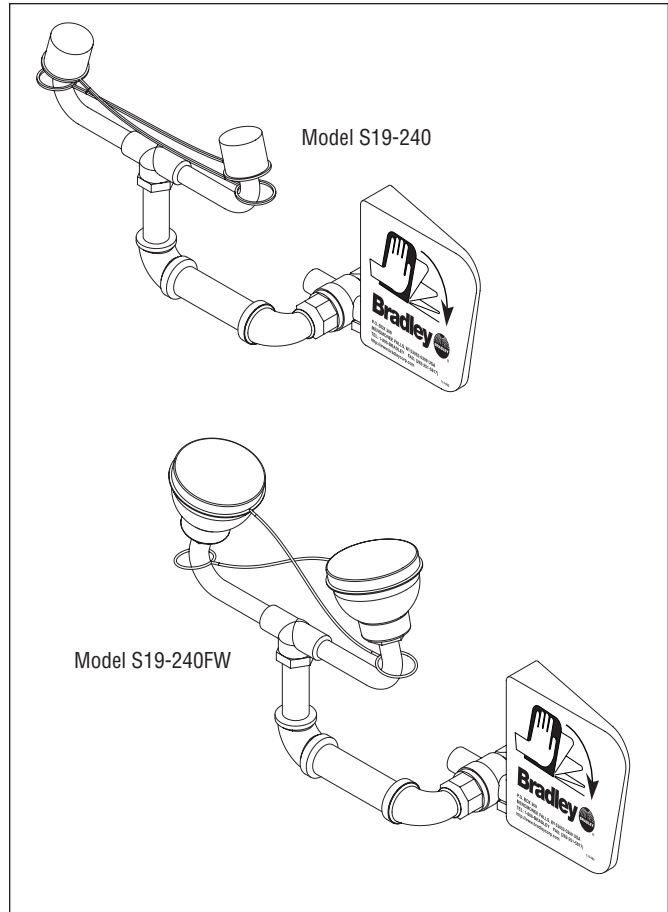

Model	Description
<input type="checkbox"/> S19-240	Laboratory Application <b>Eyewash</b> Unit
<input type="checkbox"/> S19-240FW	Laboratory Application <b>Eye/Face Wash</b> Unit

Model S19-240

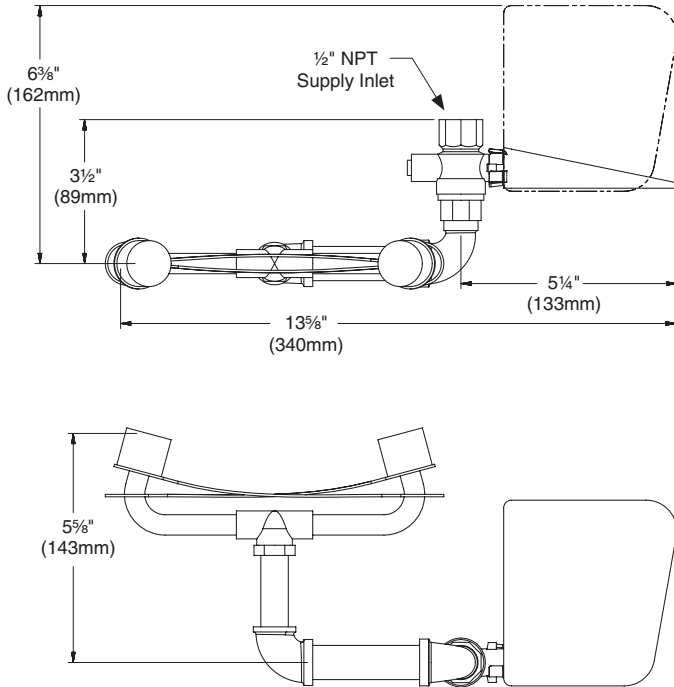

Model S19-240FW

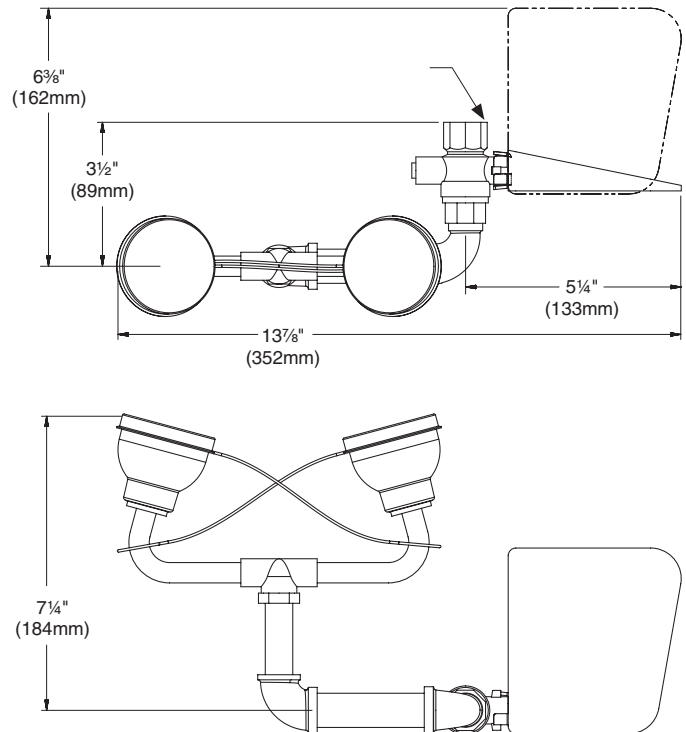

- Local codes may require the installation of a backflow prevention valve to complete proper installation. Compliance with local codes is the responsibility of the installer. Valve must be tested annually to verify that it is functioning properly. Backflow prevention valves are not included with the fixture and may be supplied by the contractor or purchased from Bradley Corporation.*
- All dimensions assume standard thread engagement. Variations in manufacturing allow for +/- 1/8" (3mm) per threaded joint. To find the tolerance of a dimension, add the number of thread joints in between a dimension and multiply it by 1/8" (3mm).*