

Specifications

Commercial Combination Stack Washer / Dryer

This washer / dryer combination maximizes facility productivity, saves space, and delivers the exceptional cleaning performance end users expect. Within the space of a single unit, the 3.1 cu. ft. washer and 6.7 cu. ft. dryer give users the capacity they need to clean even their bulkiest loads of laundry.



CET9000GQ / CGT9000GQ



CET9100GQ / CGT9100GQ

Commercial-Grade Features:

Choose a commercial-built product that withstands heavy traffic, regular use, and performs continuously.

Commercial-Grade Construction



Built with galvanized steel, the heavy-duty construction of the stack washer / dryer is designed to increase machine longevity, and handle the rigorous demands of commercial laundry.

Powerful Drive System



Designed and tested to provide more turns over the life of the washer – this machine helps owners optimize their facility's productivity, and delivers the performance customers expect. A watertight, flexible triple-lip seal with a garter spring helps keep moisture away from the shaft, protecting the premium bearings – while the durable shaft sleeve is designed to reduce shaft wear.

Automatic Load Balancing



Designed for washing efficiency, this system consists of a six-point suspension, four dampers, and two springs. By sensing and automatically balancing a load, machines are able to work effectively and end on time, creating optimized cleaning cycles and constant turns.

Microprocessor Controls



These controls offer owners the ability to customize vend prices and washer cycle options, such as Super Cycle, ensuring optimal revenue opportunities. Plus, the controls give customers the option to select the ideal cycle for individual wash needs.



ENERGY STAR® certified, and uses an average of 12.24 gallons of water per cycle* which helps reduce energy and water costs.

*Average based on DOE J2 testing with factory preset cycles.
©/™ © 2018 Whirlpool. All rights reserved.

Commercial Combination Stack Washer / Dryer



MODEL	Coin Equipped	CET9000GQ	CGT9000GQ
	Card Ready & Non-Vend	CET9100GQ	CGT9100GQ
	U.S. / Int'l	U.S. / Int'l	U.S. / Int'l
Fuel Type	Electric	Gas	
WASHER SPECIFICATIONS			
CAPACITY			
Cylinder Volume – cu. ft. (liters)	3.10 (88)	3.10 (88)	
Cylinder Diameter – in. (mm)	21.60 (547)	21.60 (547)	
Cylinder Depth – in. (mm)	13.40 (340)	13.40 (340)	
WATER INLET HOSE / DRAIN HOSE			
Operating Pressure – psi (bar)	20 – 100 (1 – 8)	20 – 100 (1 – 8)	
Inlet Hose Length – ft. (m)	4 (1.22)	4 (1.22)	
Drain Hose Length – ft. (m)	6 (1.83)	6 (1.83)	
APPROXIMATE WATER USAGE			
Average Total Water Usage Per Cycle – gallons (liters)*	12.24 (46.33)	12.24 (46.33)	
Average Hot Water Usage, Warm Water Cycle – gallons (liters)	1.5 (5.67)	1.5 (5.67)	
Average Hot Water Usage, Hot Water Cycle – gallons (liters)	2.28 (8.63)	2.28 (8.63)	
ELECTRICAL REQUIREMENTS			
Voltage	120V	N/A	
Electrical Requirements / Frequency	60Hz	N/A	
Breaker / Fuse – amps	30	N/A	
DIMENSIONS – DOOR OPENING – IN. (MM)			
14.25 (362)	14.25 (362)		
EXTRACT SPEED – MAX G-FORCE / MAX RPM			
300/1,000	300/1,000		
MOTOR SIZE – HP (KW)			
1/2 (.37)	1/2 (.37)		
INTEGRATED WATER FACTOR (IWF)*			
4	4		
MODIFIED ENERGY FACTOR (MEF₁₂)*			
2.2	2.2		
ADA-COMPLIANT			
Yes	Yes		
DRYER SPECIFICATIONS			
CAPACITY			
Cylinder Volume – cu. ft. (liters)	6.70 (190)	6.70 (190)	
Cylinder Diameter – in. (mm)	26.3 (666.8)	26.3 (666.8)	
Cylinder Depth – in. (mm)	20.4 (518.3)	20.4 (518.3)	
ELECTRICAL REQUIREMENTS			
Voltage	240V	120V	
Electrical Requirements / Frequency	60Hz	60Hz	
Breaker / Fuse – amps ⁺	30	15	
DIMENSIONS – DOOR OPENING – IN. (MM)			
18.25 (464)	18.25 (464)		
DRYER EXHAUST DUCT DIAMETER – IN. (MM)**			
4 (100)	4 (100)		
ELECTRIC HEATING ELEMENT (WATTS)			
5,600	N/A		
GAS RATING – BTU/HR. (KCAL/HR.)			
N/A	22,000 (4,544)		
GAS INLET SIZE			
N/A	3/8 NPT		
MOTOR SIZE – HP (KW)			
1/3 (.25)	1/3 (.25)		
MACHINE SPECIFICATIONS			
DIMENSIONS			
Width – in. (mm)	27 (686)	27 (686)	
Depth – in. (mm)	29.50 (751)	29.50 (751)	
Height – in. (mm)	74 (1,880)	74 (1,880)	
CRATED DIMENSIONS			
Crated Width – in. (mm)	29.25 (743)	29.25 (743)	
Crated Depth – in. (mm)	34 (864)	34 (864)	
Crated Height – in. (mm)	75.75 (1,924)	75.75 (1,924)	
APPROXIMATE WEIGHT			
Uncrated – lbs. (kg)	372 (169)	378 (171)	
Crated – lbs. (kg)	383 (173)	389 (176)	

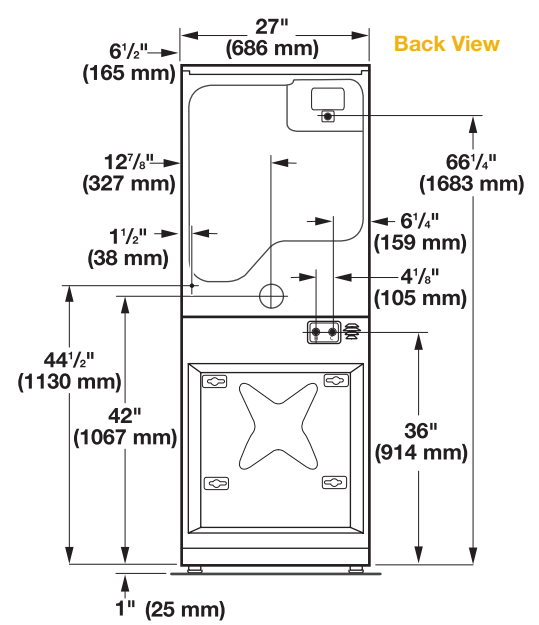
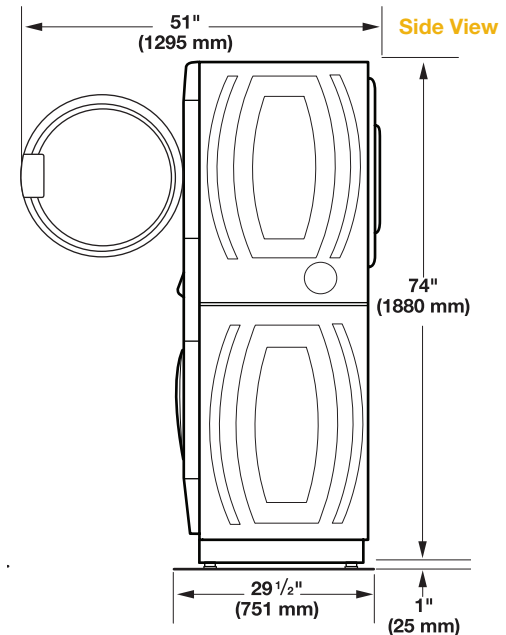

See Installation Guide for complete dimension details.



Whirlpool 2-YEAR LIMITED PARTS ONLY WARRANTY / 90-DAY LABOR

For 90 days from the date of original purchase, when this commercial appliance is installed, maintained, and operated according to instructions attached to or furnished with the product, Whirlpool Corporation (hereafter "Whirlpool") will pay for factory-specified replacement parts and repair labor to correct defects in materials or workmanship that existed when this commercial appliance was purchased. For the first two years from the date of purchase, when this major appliance is installed, maintained, and operated according to the instructions attached to or furnished with the product, Whirlpool will pay for factory-specified replacement parts to correct defects in materials or workmanship that existed when this commercial appliance was purchased. See whirlpoolcommerciallaundry.com for warranty details.

Dimensions are for planning purposes only. See specific instructions for proper installation. Because of continuous product improvement, Whirlpool reserves the right to change specifications without notice.

*Based on 2018 United States DOE J2 Testing with factory preset cycles.
 **Use 4" (100mm) diameter rigid aluminum or galvanized steel duct. Never use plastic, non-metal, or combustible duct.
 +It is recommended that a separate circuit serving only this washer / dryer be provided.